



An industry leader since 1985,  
serving businesses across North America.



# Our Commitment to your Satisfaction

Our commitment is to you, our customer, to provide the best possible service at the most enticing price. Coast to Coast is based on three fundamental principles: honesty and integrity, superior customer service and the highest environmental and quality guarantee.

Our high ethical values begin with our products going through rigorous compliance tests. We have multiple in-process Quality Assurance check points along with a final triple QA inspection. Each toner cartridge is assigned a unique barcode and is print tested and verified before shipping. Also, we continuously life test using simulated shipping and environmental conditions.

When you partner with Coast to Coast, your customized service will be provided by your personally appointed salesperson. Our expert staff continuously attends ongoing training and will work with you to analyze your needs and offer you a variety of solutions.

Our Diamond Series™ compatible cartridges are environmentally friendly. Each Diamond Series™ toner cartridge saves 3.5 quarts of oil and eliminates 3.5 lbs. of plastics and metals from potentially entering our landfills. By partnering with Coast to Coast, you are helping save the planet, beginning with the first page you print!

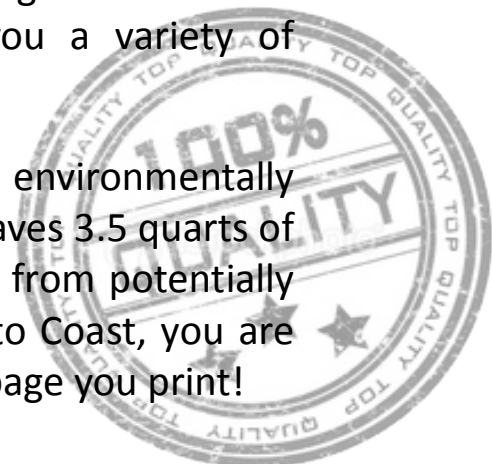

# Coast to Coast History

## Serving North America for over 25 Years

- Consumable imaging supplies
- Consistent, high-quality products
- OEM alternative cartridges
- Competitive pricing
- Recognized as an Industry Leader with an A+ rating by the Better Business Bureau



## 100% Customer Service Driven

- Highly trained account managers
- Personally customized service
- Lasting partnerships
- Constant dedication



## Diamond Series™

- OEM alternative cartridges
  - Documented 99.2% product satisfaction rate
- **Manufactured in the U.S.A.**
- Large inventory, over 400 SKU's
- **More environmentally friendly**

# Diamond Series™ Cartridge Technologies



**Monochrome Toner Cartridges**



**Color Toner Cartridges**



**Diamond Series™ Elite Cartridges**



**Specialty MICR Toner Cartridges**

PRINT HEAD

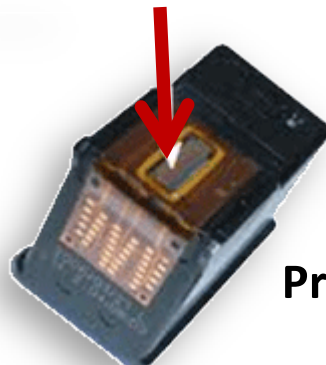

**Print Head Based Inkjet Cartridges**

# Diamond Series™ Comparison

**Coast to Coast Products Increase the Yield**

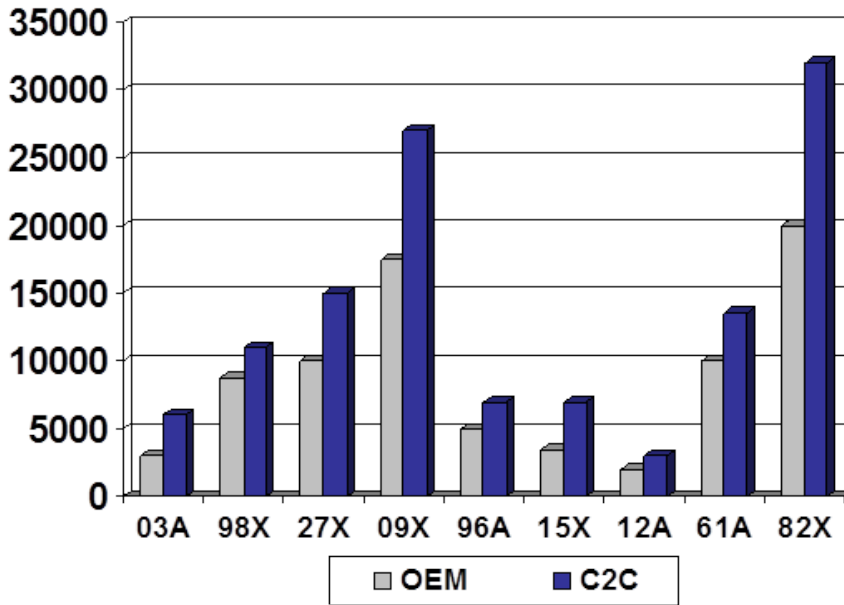

## Diamond Series™ vs. OEM and Refilled Cartridges

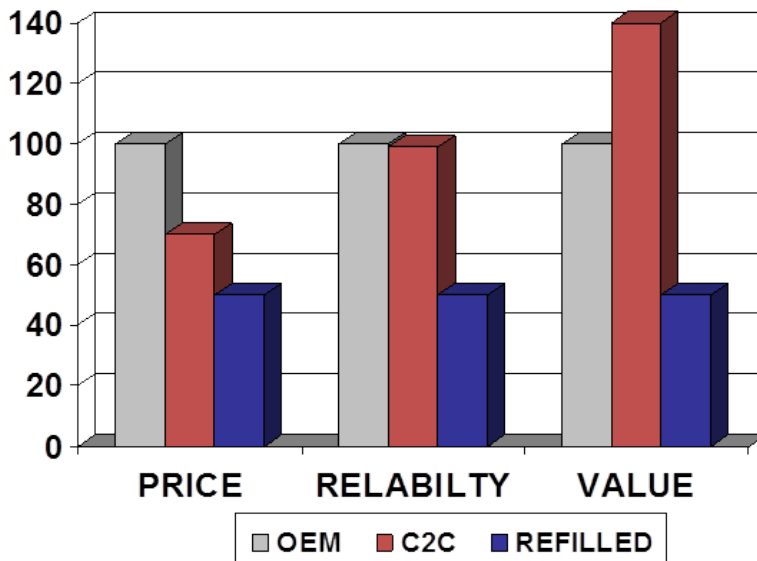

# Diamond Series™ Exclusive

## 10-Step Manufacturing Process

- 1. INCOMING RAW MATERIALS INSPECTION** - All materials, drums, toner, blades, primary charging rollers, magnetic rollers, etc... are verified against our rigorous standards before they reach the production floor
- 2. SORT and GRADE** - All empty cartridges are sorted and graded. Only premium empty cartridges are used in our products. This assures the surpassed quality of the finished product.
- 3. RECYCLE** - All used packaging materials, used hopper and non-conforming components are disassembled and recycled to help protect our environment.
- 4. SPLIT & CLEAN** - Premium empty cartridges are carefully disassembled and cleaned with our unique state-of-the-art process. Through automation we can precisely split the toner hopper with custom splitting equipment and prepare them for sealing.
- 5. DIGITAL AUTO FILLING** - State-of-the-art automated filling equipment is used to ensure precise fill weights for each cartridge. Toner hoppers are filled with premium toners, which are technically matched to the OPC drum for optimal yields and printer performance.
- 6. SEALING** - Each toner hopper is sealed with an OEM style seal. Our quality sealing process ensures a leak-proof cartridge and ease of installation for the consumer.
- 7. ASSEMBLY** - Our expert technicians assemble all cartridges with OEM grade compatible components (up to 75% new components are used in each cartridge). The assembly process includes installation of a pre-qualified drum, wiper blade, doctor blade, primary charging roller and magnetic roller.
- 8. 100% POST TESTING** - Each and every cartridge is post tested utilizing industry standard print tests to ensure outstanding performance and quality.
- 9. PACKAGING** - All cartridges receive a final inspection to assure they conform with our quality standards. Cartridges are cleaned, polished, heat-sealed in a static resistant bag and then boxed. A full set of instructions and warranty information is included.
- 10. QUALITY CONTROL** - Each step in our manufacturing process is monitored by dedicated Quality Control experts, who undergo regular and rigorous spot inspections to ensure our products will meet the expectations of our partners.

# Superior Color Cartridges

1. **Splitting System:** Splitting equipment does not remove plastic or cut through OEM alignment pins like standard rotary blade splitting systems. This allows precision realignment during manufacturing, results in superior cartridge integrity and eliminates leaking.
2. **Cartridge Welding:** Cartridge welding technologies ensure exact OEM realignment, eliminates human error and the need for clips. Cartridge welding also eliminates leaking. There are 70 models welded including both laser and inkjet cartridges.
3. **Pin Removal System:** Manufacture red using a special technology to remove pins without drilling. This eliminates cartridge wobble caused by improper removal.
4. **Toner Formulations:** Color matching toner formulations ensure proper image matching and accurate color density without hazing or back-grounding.
5. **Seal:** Seal ensures the product arrives leak-free and pulls completely out easily without leaking or cartridge, “sweating”.
6. **OPC Drum:** Drums are specifically optimized and available only on our cartridge products. They are specially matched to our toner and ensure color matching and image density.
7. **Doctor Blade Treatment:** Blade treatment ensures images are more consistent and toner is delivered/dispersed evenly.
8. **Adder Roller Treatment:** Adder roller treatment evenly supplies toner to the developer roller/sleeve to produce consistent image density and accurately matched colors.
9. **Wiper Blade:** OEM-type wiper blade correctly cleans the OPC and ensures proper toner transfer to the waste hopper.
10. **Full Chip Solution:** Chips that offer identical functionality to that of the OEM are used on all cartridges which utilized a chip as part of the OEM specification. Our chips deliver superior reliability and true original compatibility.
11. **Gasket Sealing System:** To eliminate leakage, cartridges are manufactured using automated and robotic equipment to apply a continuous gasket seal, which is also waterproof.
12. **Toner Evacuation Technologies:** To eliminate potential cartridge leaking and/or “sweating” during transport, multiple patent-pending systems were developed to remove any excess toner after post testing.

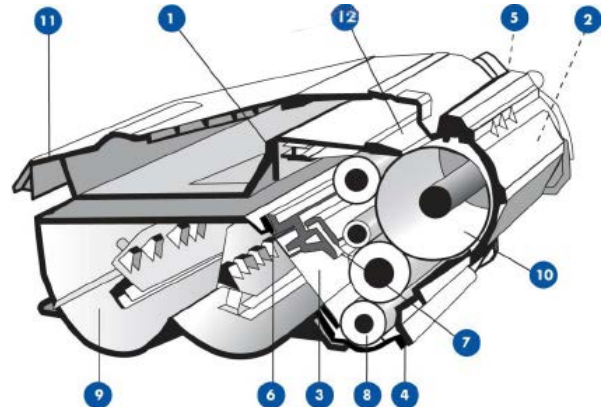

## Coast to Coast has set the standard for quality!

Toner cartridge manufacturers use various methods for testing and reporting the quality of their products. The traditional method uses “5% page coverage”, an estimated yield based on print sampling and the toner consumed. The major downfall of this and other traditional test methods is that it does not account for variables that affect the page yield nor does it evaluate the quality or life of the cartridge. In order to verify the remanufacturer has used proper procedures to benchmark their product’s performance, quality and cartridge yield, we have established the following criteria that is supported only by OEM and the highest remanufacturers of print cartridges.



ISO 9000 is a family of standards for quality management systems. Some requirements in the ISO 9001 standard include: Documenting

procedures, monitoring processes, keeping adequate records, taking corrective action, regularly reviewing the overall system and the facilitation of continuous improvement. The idea is to establish systems improving product quality and reliability.



ISO 14000 environmental management standards help organizations minimize how their operations negatively affect the environment through an environmental

management system (EMS). It specifies the requirements for establishing an environmental policy, determining environmental impact, planning and implementation as well as documented, continuous improvement.



ISO 19752 standard is a standardized page yield test for monochrome (b/w) laser printer cartridges. The test is done with a minimum of nine cartridges

tested on three separate printers with a standard print/test page under specific environmental conditions and printer settings.



The ISO 19798 standard is a standardized page yield test for color laser printer cartridges. The test is done with a minimum of 12 cartridges (three sets of CMYK) tested on three separate printers with a standard set of five different print/test pages under specific environmental conditions and default printer settings.



Standardized Test Methods Committee (STMC) is a global committee formed to find and

promote the standardized test methods for the printer cartridge industry. STMC testing incorporates a page yield test as well as packaging integrity parameters.



Historically, compatible toner cartridges made in the U.S.A. have been the highest quality available. You also benefit with prompt delivery and can visit where your product is made to better understand quality. Our products are proudly manufactured in California.

It is imperative to select a manufacturer who stands behind their products unconditionally. Look for extended warranties and manufacturers who back their product. In case of potential cartridge failure, look for manufacturer’s warranty that covers both your cartridge AND your machine in case something in the cartridge damages the machine.



The Accredited Standards Committee X9 (ASC X9) has the mission to develop, establish, maintain and promote the standards for the Financial Services Industry. Look for products made by companies who are members of the X9 MICR standards committee.





# Extended Warranties

## OEM Warranty

Most major brand OEM (Original Equipment Manufacturer) companies only offer a **ONE-YEAR, limited** warranty.



## Coast to Coast Warranty

Diamond Series™ toner cartridges have a **TWO-YEAR, 100%** warranty and we cover your machines when you use our products.



### The Coast to Coast Warranty

When you partner with Coast to Coast Computer Products, Inc.™ you can expect ultimate satisfaction and reliability. We offer a two-year, 100% quality guarantee on our Diamond Series™ toner cartridges, available exclusively at Coast to Coast.

#### About Diamond Series™ Toner Cartridges

All Diamond Series™ cartridges must pass rigorous compliance tests and are certified under the ISO 9001/14001 Quality and Environmental System, as well as being STMC certified. All incoming components are inspected prior to being released into production. Engineers analyze toners, measure seals and blades and even modify many incoming components to enhance their performance to meet or exceed OEM (Original Equipment Manufacturer) specifications.

#### What Does This Warranty Cover?

The two-year\* Coast to Coast warranty covers your Diamond Series™ toner cartridge as well as the integrity of the machine you are running it in. In the unlikely event that a Diamond Series™ toner cartridge should cause damage, contact your sales representative at Coast to Coast immediately. They will either set up a service appointment (if required) or work with you on an approved technician of your choice.

If any damage to your printer is found, the technician must state in writing that damages are due to a Coast to Coast product in order to receive repair, replacement or reimbursement of service, parts or equipment. All defective toners can be returned for credit within the two-year warranty period. Returns will only be accepted with a return authorization. Coast to Coast's liability shall be limited to repair, replacement or reimbursement, as stated above. This warranty is exclusive and in lieu of any and all other warranties, expressed or implied.

\*Diamond Series™ toner cartridges are guaranteed for two years from the invoice date.

[www.coastcoast.com](http://www.coastcoast.com) | 4277 Valley Fair St., Simi Valley, CA 93063 | 800.223.8890

Copyright © 2011 Coast to Coast Computer Products, Inc. All rights reserved.





# Coast to Coast Computer Products, Inc.™ also carries:

- Laser, inkjet, impact, datacenter and thermal printers, supplies and maintenance
- Printer ribbons, print heads and print bands
- Network hardware and surveillance equipment
- Data tapes, storage drives, libraries and duplicators
- Fax and copier machines and supplies
- Scanning and barcode equipment and supplies
- Servers, server parts and power supplies
- Projectors, lamps and bulbs
- Mailroom equipment and shipping supplies
- Office supplies and stationary
- IT supplies

**Call your Sales Representative at 800.223.8890  
to learn how we can simplify your  
job and save you money!**